

# BittWare WaveBox-119 RF System >

The BittWare WaveBox-119 is an AMD Versal™ RF VR1902 chip in a commercial 1U chassis with NEBS 3 environmental specifications. It is a cost-optimized platform for commercial satellite base station applications or a development kit for defense applications.



Preliminary product concept image

This 1U server implementation of the AMD Versal RF device features direct RF up to 8 GHz (balun's limit). The Versal RF VR1902 chip features 4 GHz of instantaneous bandwidth along with 16x ADCs and DACs. This device offers significantly more FPGA programming resources and digital I/O bandwidth than previous generation cards based on UltraScale+ RFSoc. A single WaveBox-119 provides more resources than multiple typical RFSoc cards, as well as the FPGA card users often deploy alongside, potentially offering better analog performance in a smaller space for less money.

## Preliminary Product Info

The BittWare WaveBox-119 includes a reference application providing VITA 49.2 over Ethernet (a DIFI subset). Additional data plane protocols are available through our IP Partner eco-system such as Aurora, Ethernet MAC frames, RoCE v1 RDMA, and UDP.

## FEATURES AND ADVANTAGES

**Integrated amplification and filtering**  
Higher performance and reduced cost

**AMD Versal RF adaptive SoC**  
Direct RF up to 8 GHz (balun limit) and ARM processing subsystem

**16x in/out in 1U Chassis**  
High-density from a single direct RF chip

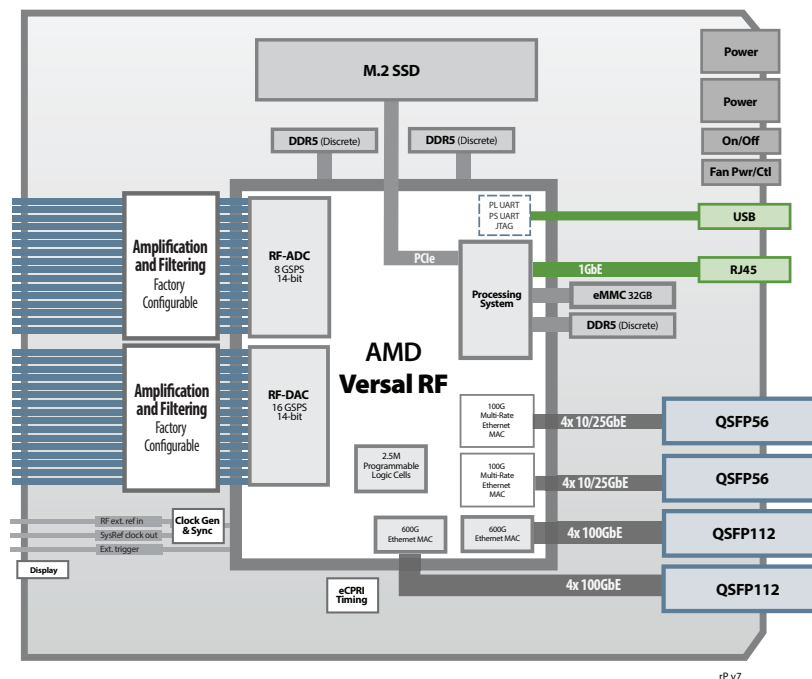

Simplified diagram not showing all features under consideration.

# BittWare WaveBox-119 RF System >

## PRODUCT DETAILS

### ADC Front End Options

The Versal RF chip at 8 GSPS offers 4 GHz instantaneous bandwidth at up to 8 GHz (balun limit). To address aliasing challenges requiring filtering in the path, the WaveBox-119 features on-card filtering and amplification. The front end is optimized for 1st Nyquist: 500 MHz to 3.5 GHz on the ADC side, and 500 MHz to 7.5 GHz on the DAC side. A wideband configuration may be available for customers willing to provide all filtering and amplification external to the card. Contact us for details.

Our implementation allows users to inject power and a 10 MHz reference signal into all ADC and DAC channels. This eliminates external boxes that do the same thing in many configurations.

### How the ADC/DAC Configuration Options Work

*Each card is factory-configured for one set of 16x input and 16x output options*

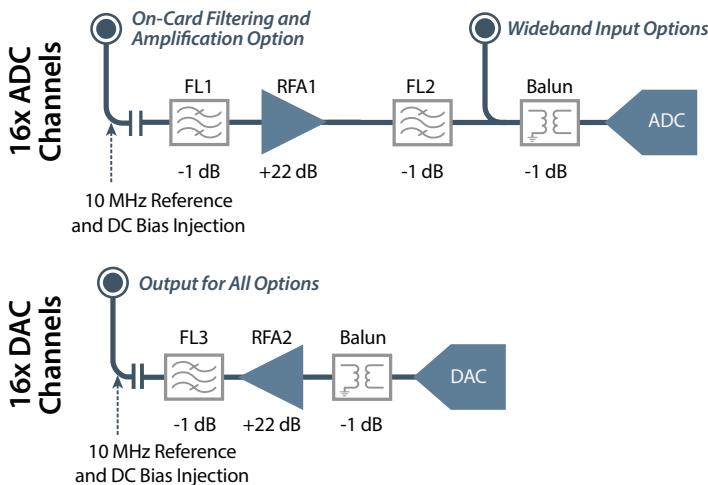

### Analog Characterization Data

Molex fully tests and documents the analog characteristics of each WaveBox-119 configuration. That data is available for most revisions through our developer website.

### Included IP

The BittWare WaveBox-119 servers ship with a reference application that converts between analog data and timestamped, VITA-49.2 packets. It works in both ADC and DAC directions. The application also transfers raw data to and from ARM memory.

The direct RF chip's ARM Processing System runs Linux and acts as a control plane. More specifically, we have integrated card management functions through customized Linux drivers. Molex has also ported AMD's RF Tool application, a socket library that configures a direct RF chip. Above both Linux and RF Tool, we provide our own RFUtils commands and examples. RFUtils can generate synthetic waveforms as well as load and stream waveforms from files. All of this is fully supported by Molex, and we provide source code.

Molex created a GUI tool called RFX Surfer to help configure and monitor RFX and WaveBox-119 cards, as well as analyze data. We use RFX Surfer to automate RFX performance characterization, including automating external test equipment. It communicates over Ethernet to a socket server running on the ARM PS. VRF-319 cards include this utility, with source code.

The WaveBox-119 reference application moves VITA-49 data over VPX data planes. The application supports VITA-49 in Ethernet frames and Aurora frames. DIFI uses a specific VITA-49 subset over UDP. We have demonstrated a variation of our reference application that includes the Atomic Rules UDP Offload Engine.

With respect to the PCIe interface, our reference application can also move VITA-49 data over PCIe using the AMD QDMA in conjunction with the AMD QDMA Linux drivers. Also available for the WaveBox-119 is a version of Atomic Rules Arkville which is higher performance over PCIe and sends the data all the way to disk.

### Target Environment

The WaveBox-119 provides a next-generation option for users of BittWare RFX-880 products. It offers significantly higher analog performance at slightly lower price point than current BittWare RFX-880 users pay for systems with multiple RFX-880 cards along with a BittWare XUP-VV8 FPGA processing card.

The WaveBox-119 box is ideal as a development platform for Versal RF VR1902 chip-down designs or for customers considering the Versal RF in defense VPX form factors.

# BittWare WaveBox-119 RF System >

## SYSTEM SPECIFICATIONS

### Versal RF

- AMD Versal RF
  - VR1902 (8 GSPS)
  - Core speed grade -2

### Processing Subsystem (PS)

- Application Processing Unit Quad-core Arm Cortex-A72 MPCore
- Real-Time Processing Unit Dual-core Arm Cortex-R5F MPCore

### Analog

- 16x 8 GSPS 14-bit ADCs
  - **Standard ADC config** is 500 Mhz to 3.5 Ghz with bandpass filters and +22 dB of gain
  - **Unamplified build option** provides -3 dB gain from 10 MHz to 8 GHz (default)\*
  - Max input power +15 dBm
- 16x 16 GSPS 14-bit DACs
  - The standard DAC config is 500 Mhz to 7.5 Ghz with bandpass filters and +22 dB of gain at max output power of +15 dBm.
  - Range of +15 to +10 dBm (this level is a function of frequency)
  - Constrained by a 7.5 GHz LPF in 1st Nyquist zone (FL3)
- Programmable clocks
- External reference and triggers
- Can inject a 10 MHz reference and power into all ADC and DAC channels

### M.2 SSD Slot

- Slot for NVMe PCIe M.2 SSD

### On-board flash

- PS connects to a pair of 2Gb QSPI parts configured in "Dual Parallel" mode. The PS boots from the QSPI to configure itself, then pulls the logic bitstream from the QSPI and configures the PL
- 32GB eMMC for ARM disk

### External memory

- Processing system: 16GB, 64-bit DDR5 with ECC
- Programmable logic: 32GB, 2x banks 64-bit DDR5 with ECC (our example uses it as 36GB no ECC, 72-bit)

### Front I/O Ports

- 16x SMA for ADC
- 16x SMA for DAC
- 4x BNC for clocks and triggers

### Rear I/O Ports

- 2x QSFP112 cages connected to 2x Versal RF 600G Ethernet MACs; each cage supports 4x 100GbE or 1x 400GbE to a switch
- 2x QSFP56 cages connected to 2x Versal RF 100G Ethernet MACs; each cage can support 100/50/25/10GbE
- RJ-45 for the ARM PS
- USB-C for programming
- On/off switch

### Electrical

- 2x power supplies
- Power dissipation is application dependent

### Import/Export

- Exports of this system from the US will require a license for some countries

### Form factor

- 1U chassis

## DEVELOPMENT TOOLS

### Firmware development

Molex provides interface software support for an example bitstream that fully configures the Versal RF chip using a scripting language running on the Versal RF ARM. AMD Vivado development tools are fully supported for development of custom designs.

### Application development

- Ubuntu 24.04 LTS
- Yocto (subject to change)

\* The Versal RF chip supports much higher frequencies. The WaveBox-119 Wideband is constrained by the balun and connector system. Higher band support is possible in special orders.



Embedded  
Partner  
Network

PLATINUM

To learn more, visit [bittware-molex.com](https://bittware-molex.com)

Versal is a trademark of AMD Corp. All other products are the trademarks or registered trademarks of their respective holders.

rP v3 | last revised 2026.07.02 © Molex 2026