

# BittWare RFX-880 RFSoc Ethernet Card

The BittWare RFX-880 card is a digital direct sampling transceiver featuring the third generation AMD Zynq® UltraScale+™ RFSoc.

This innovative solution uses the RFSoc for direct sampling between 50 MHz and 6 GHz. The card optionally integrates filters and amplification, displacing external devices, which results in higher performance and reduced cost. The AMD Zynq® UltraScale+™ RFSoc integrates RF-class A/D and D/A converters into the Zynq® FPGA fabric and multi-core ARM processor subsystem, creating a multi-channel data conversion and processing solution on a single chip.



## FEATURES AND ADVANTAGES

### Integrated amplification and filtering

Higher performance and reduced cost

### 400 Gbps digital I/O via QSFP-DDs

Ideal for high-bandwidth RFSoc implementations

### Third generation AMD Zynq® UltraScale+™ RFSoc

Direct sampling between 50 MHz and 6 GHz

### Standalone PCIe form factor

Use standalone, install in ruggedized chassis or mount in traditional PCIe slot

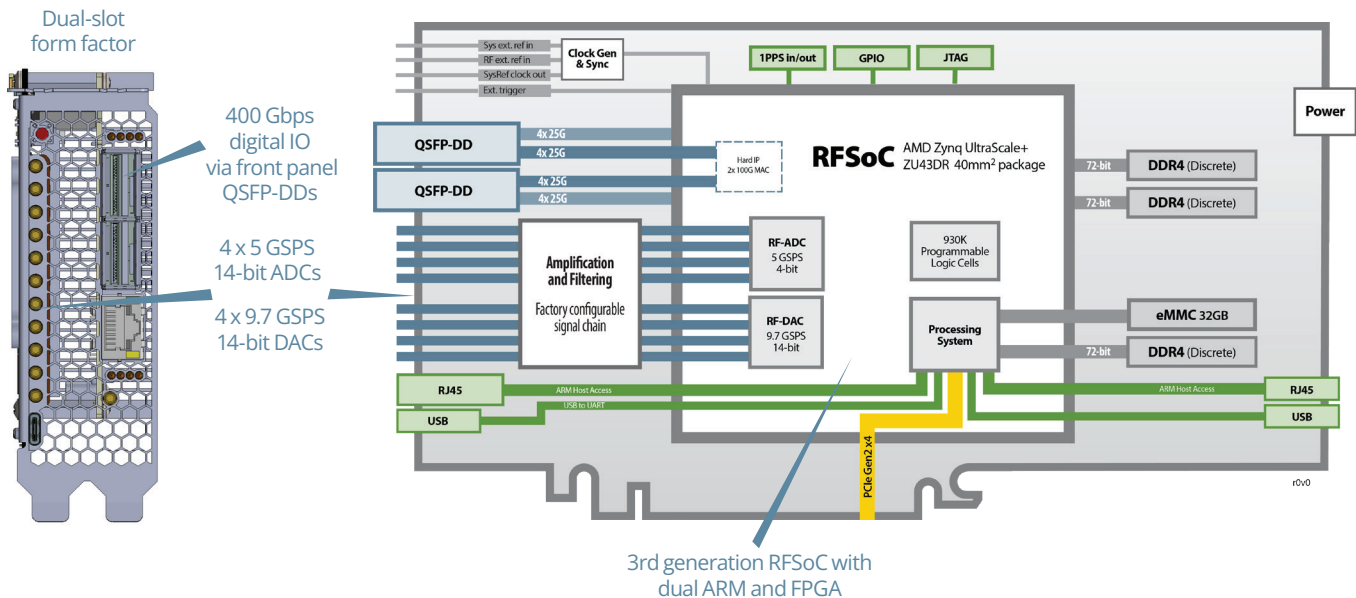

# BittWare RFX-880 RFSoc Ethernet Card

## CARD DESCRIPTION

### Standalone PCIe Form Factor

The RFX-880 was designed as a standalone card that just happens to be in PCIe form factor. Installing the card in a ruggedized chassis allows you to mount the RFX-880 card near the antenna to transform antenna data into packets.

Since the RFX-880 gets all of its power via the external power connector and can be communicated with via an on-board RJ45 connector, it does not need a PCIe slot. The card is available integrated in our optional WaveBox Gamma, a chassis specifically optimized for the RFX-880. The card also works in traditional server PCIe slots, with PCIe supplementing Ethernet as a control plane.

### 400 Gbps Digital I/O

With 400 Gbps of digital I/O available on the FPGA side of the RFSoc, the card supports four times the bandwidth of RFSoc implementations that depend upon PCIe for data transfer. This I/O is available through two QSFP-DD ports. Customers have implemented transports using Aurora, Ethernet MAC frames, RoCE v1 RDMA, and UDP, including NVIDIA Holoscan Sensor Bridge protocol directly into some GPUs. The BittWare reference application provides VITA 49.2 over Ethernet (a DIFI subset).

The RFX-880 is popular with customers building satellite base stations. In this application, RFX 880 translates analog data into a DIFI packet stream.

### ADC Front End Options

The RFSoc chip at 5 GSPS offers a 2.5 GHz bandwidth at up to 6 GHz. Aliasing challenges require filtering in the path. The RFX-880's "Wideband" configuration targets customers willing to provide all filtering and amplification external to the card. The RFX 880 also offers build options for on-card filtering and amplification with filters available for Nyquist 1, 2 and most of 3.

## Clock Tree

The RFX-880 card offers a very flexible clock tree. It can accommodate reference clock inputs from Synchronous Ethernet, eCPRI, CPRI, as well as reference clocks fed in directly over coax cables. The default card configuration also has a 10 MHz OCXO and a 125 MHz fixed VCXO. Some of the RFX 880 clock tree flexibility is established through build options when the card is manufactured. We will configure optimized cards for each customer, with a minimum quantity requirement in each order.

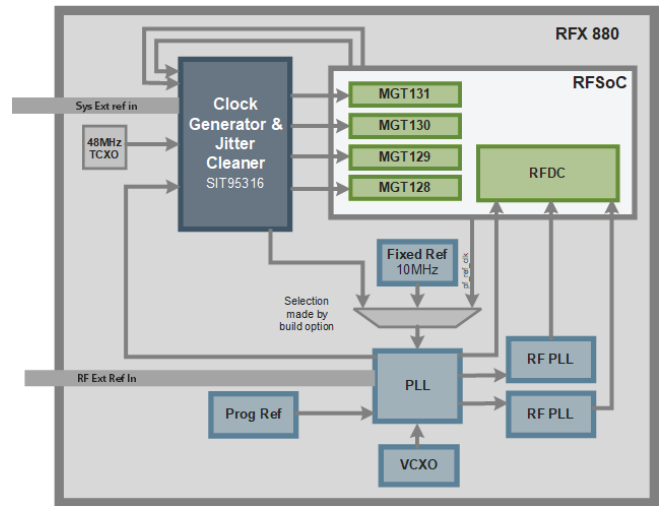

## How the ADC/DAC Configuration Options Work

Each card is factory-configured for one set of 4x input and 4x output options

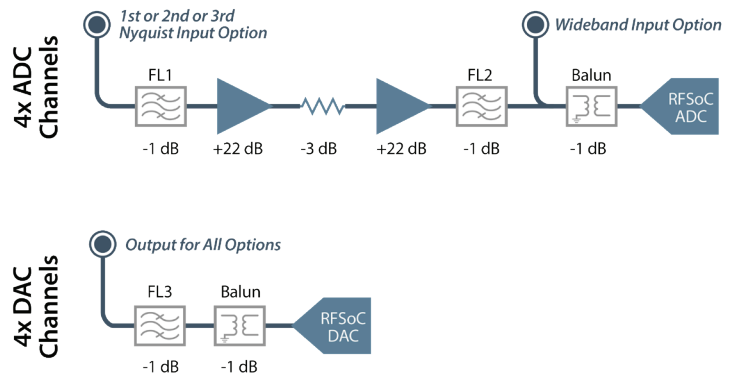

# BittWare RFX-880 RFSoc Ethernet Card >

## Included IP

BittWare RFX cards ship with a reference application that converts between analog data and timestamped, VITA-49.2 packets. It works in both ADC and DAC directions. The application also transfers raw data to and from ARM memory.

The RFSoc's ARM Processing System runs Linux and acts as a control plane. More specifically, we have integrated card management functions through customized Linux drivers. We have also ported AMD's RF Tool application, a socket library that configures an RFSoc chip. Above both Linux and RF Tool, we provide our own RFUtils commands and examples. RFUtils can generate synthetic waveforms as well as load and stream waveforms from files. We fully support and provide source code for all of these features.

We provide a GUI tool called RFX Surfer to help configure and monitor RFX cards, as well as analyze data. We use RFX Surfer to automate RFX performance characterization, including automating external test equipment. It communicates over Ethernet to a socket server running on the ARM PS. RFX cards include this utility, with source code.

The BittWare RFX-880 reference application moves VITA-49 data over cables or transceivers plugged into QSFP-DD. The application supports VITA-49 in Ethernet frames and Aurora frames. DIFI uses a specific VITA-49 subset over UDP. We have also demonstrated a variation of our reference application that includes Atomic Rule's UDP Offload Engine.

## Analog Characterization Data

Molex fully tests and documents the analog characteristics of each RFX-880 configuration, whether wideband or amplified. That data is available for each significant printed circuit board (PCB) revision, roughly one month after a new PCB passes through manufacturing. The reports are available to customers through [developer.bittware.com](http://developer.bittware.com).

## Exceeding the RFSoc Specification

AMD tests each RFSoc chip to 6 GHz. However, our characterization reports show that the full third Nyquist, up to 7.5 GHz performs well with an additional 3 dB of gain roll-off from 6 to 7.5 GHz in the ADC. The roll-off between 6 and 7.5 GHz is acceptable for many applications.

AMD also offers RFSoc chips screened for faster rates. AMD SCD 5814 increases the DAC from 9.8 GSPS to 10 GSPS. In addition, The ZU58DR, a limited distribution version of the ZU48DR, can run the ADCs at 5.4GSPS. These and other options are available for minimum order quantities and at different price points and business terms, passed through from AMD.

## Chassis Options

Our WaveBox Gamma chassis holds up to three RFX-880 cards in 1U. There is no motherboard inside. Alternatively, if you want to control the RFX-880 over PCIe, use the BittWare WaveBox Sigma chassis. Both versions of WaveBox require an RFX-880 that isn't as wide as a standard, dual-slot PCIe card. If you wish to provide your own chassis, you can order the RFX-880 built a little wider to fit into a generic server's PCIe backplane.



**WaveBox**

# BittWare RFX-880 RFSoc Ethernet Card >

## SYSTEM SPECIFICATIONS

### RFSoc

- AMD Zynq UltraScale+ RFSoc
  - XCZU43 in a G1517 package
  - Core speed grade -2

### Processing Subsystem (PS)

- Application Processing Unit Quad-core Arm Cortex-A53 MPCore at 1.2 GHz
- Real-Time Processing Unit Dual-core Arm Cortex-R5F MPCore at 525 MHz

### Analog

- 4x 5 GSPS 14-bit ADCs
  - **Wideband build option** provides +0 to -27 dB gain from 50 MHz to 6 GHz (or 7.5 GHz) with no filtration
  - **1st Nyquist (L-Band) build option** provides +41 to -29 dB on all 4 channels, constrained between 400 MHz and 2.5 GHz by filters FL1 and FL2
  - **2nd and 3rd Nyquist** filters are also available on amplified channels as a special order
  - Max input power -22 dBm on the amplified version and +15 dBm on the wideband
- 4x 9.7 GSPS 14-bit DACs
  - Range of +3 to -24 dBm (high power end of this range is a function of frequency)
  - Constrained by a 4.8 GHz LPF (FL3)
- Balun used in both ADC and DAC channels begins its frequency roll-off at 6 GHz (Rev 0 cards) or 8 GHz (Rev 1+ cards)
- Programmable clocks
- External reference and triggers
- Push-on SMPM connectors:
  - Rev 0 cards have push-on, FD SMPM connectors
  - Rev 1+ cards have push-on, threaded, FD SMPM connectors

\* Support for QSFP-DD modules at up to power class 5

### On-board flash

- PS connects to a pair of 2Gb QSPI parts configured in "Dual Parallel" mode. The PS boots from the QSPI to configure itself, then pulls the logic bitstream from the QSPI and configures the PL
- 32GB eMMC for ARM disk

### External memory

- Processing system: 16GB, 64-bit DDR4-2400 with ECC
- Programmable logic: 32GB, 2x banks 64-bit DDR4-2400 with ECC (our example uses it as 36GB no ECC, 72-bit)

### External digital interfaces

- Processing system
  - PCIe Gen2 x4
  - Dual RJ45 Ethernet, one on the front panel, second inside the chassis
  - Single USB for UART and JTAG, dual connectors. One on the front panel, second inside the chassis
- Programmable logic:
  - Up to 400 Gb/s available via front panel 2x QSFP-DD\*
  - AMD Hard IP support for dual 100GbE
- 4x bidirectional General Purpose I/O pins (GPIO)
  - TTL 3.3 volt and are 4.6 volt tolerant

### Cooling

- Standard: double-width passive heatsink
- Contact us for other cooling options

### Electrical

- On-board power derived from 6-pin AUX connector
- Power dissipation is application dependent
- Typical max power consumption 50W

### Environmental

- Designed to operate between +5C and +40C chassis air inlet temperature, noncondensing (air temperature inside the chassis between +5C and +60C)
- Storage temperature: -35°C to +85°C
- Storage humidity: 5% to 95% RH, (non-condensing)
- Operating humidity: 25% to 75% RH, (non-condensing)

### Quality & Compliance

- Manufactured to IPC-A-610 Class 2
- RoHS compliant
- CE, FCC, UKCA & ICES approvals

### Import/Export

- Exports of this card from the US will require a license for some countries

### Form factor

- Standard height PCIe dual slot card (x16 mechanical)
  - Rev 0 cards: 267 mm long
  - Rev 1+ cards: 254 mm long (3/4 length)
- Supports standalone operation
- The Molex WaveBox Gamma chassis was specifically designed to house RFX 880 cards

## DEVELOPMENT TOOLS

### Firmware development

We provide interface software support for an example bitstream that fully configures the RFSoc chip using a scripting language running on the RFSoc's ARM. AMD Vivado development tools are fully supported for development of custom designs.



## SALES PART NUMBERS

For **initial evaluation**, we urge customers to buy an RFX-880 integrated into a WaveBox Gamma chassis.

RFX-880-0003	RFX-880 Wideband card for standard PCIe chassis
RFX-880-0005	RFX-880 1st Nyquist amplified card for Wavebox
RFX-880-0007	RFX-880 1st Nyquist amplified card for standard PCIe chassis

Interested in purchasing? We offer direct sales at [bittware.com](http://bittware.com), or you can check stock with our distributors at [bittware.com/rfx880](http://bittware.com/rfx880).

To learn more, visit [bittware.com](http://bittware.com)

UltraScale+, Zynq, and RFSoc are registered trademarks of AMD Corp. All other products are the trademarks or registered trademarks of their respective holders.