

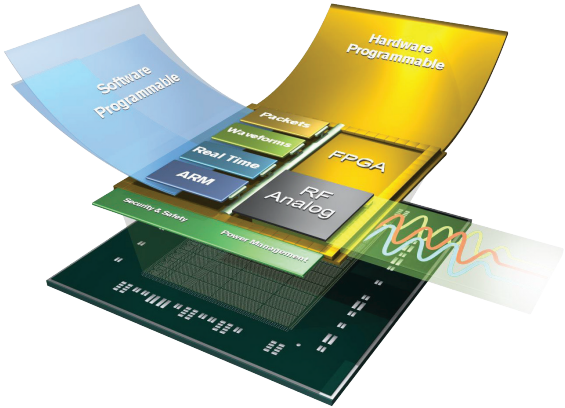

RFSoc Transceiver Card with 400 Gbps Digital I/O

Available with optional amplification and filtering on the card

The BittWare RFX 880 card is a digital direct sampling transceiver featuring the third generation AMD Zynq® UltraScale+™ RFSoc. This innovative solution uses the RFSoc for direct sampling between 50 MHz and 6 GHz. Our card implementation optionally integrates filters and amplification, displacing external devices. Integrating this on the card results in higher performance and reduced cost. The RFX 880 was designed as a standalone card that just happens to be in PCIe form factor. Installing the card in a ruggedized chassis allows you to mount the RFX 880 card near the antenna to transform antenna data into packets. Since the RFX 880 gets all of its power via the external power connector and can be communicated with via an on-board RJ45 connector, it does not need a PCIe slot. The RFX 880 also works in traditional server PCIe slots.



The AMD Zynq® UltraScale+™ RFSoc integrates RF-class A/D and D/A converters into the Zynq® FPGA and multi-core ARM processor subsystem, creating a multi-channel data conversion and processing solution on a single chip.

With 400 Gbps of digital I/O available on the FPGA side of the RFSoc, the card supports four times the bandwidth of RFSoc implementations that depend upon PCIe for data transfer. This I/O is available through two QSFP-DD ports. Customers have implemented transports using Aurora, Ethernet MAC frames, and UDP.

key features

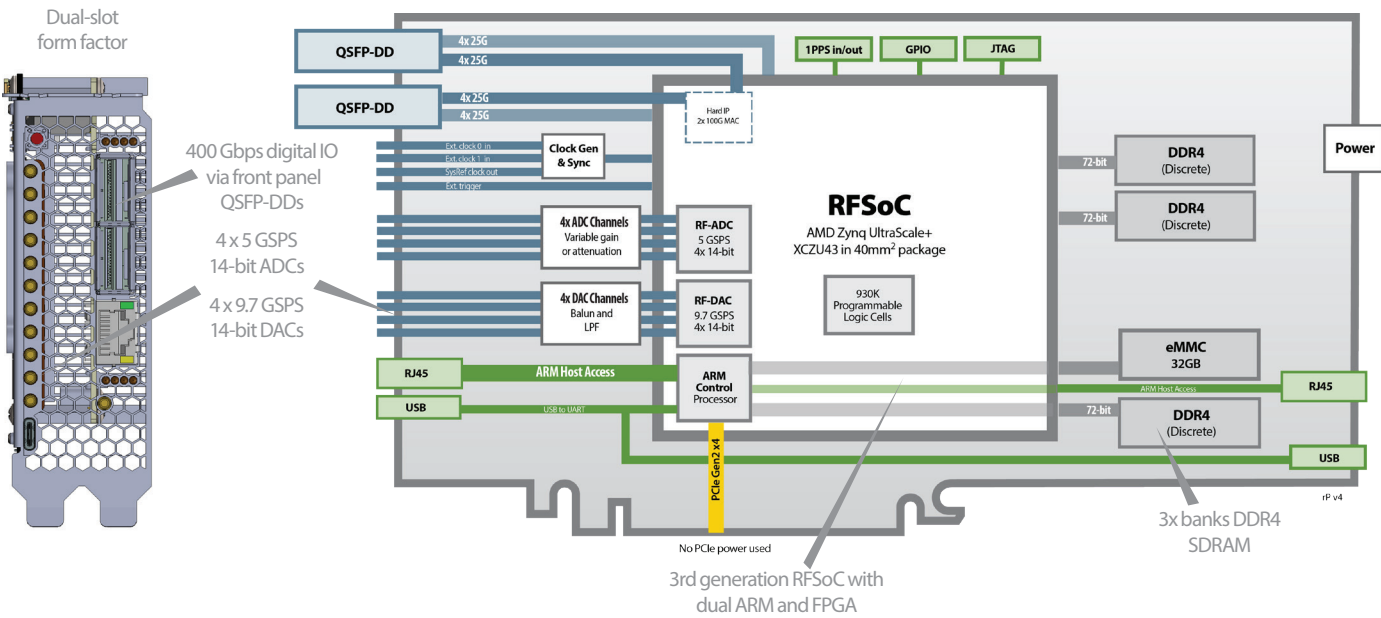
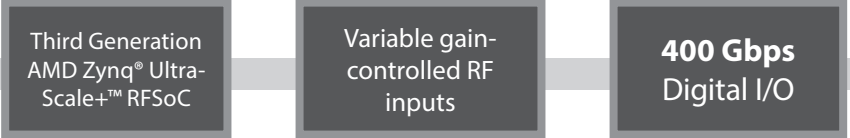

RFX 880

Ethernet RFSoc Card

ADC Front End Options

The RFSoc chip at 5 GSPS offers a 2.5 GHz bandwidth at up to 6 GHz. Aliasing challenges require filtering in the path. The RFX 880's "Wideband" configuration targets customers willing to provide all filtering and amplification external to the card. The RFX 880 also offers build options for on-card filtering and amplification with filters available for Nyquist 1, 2 and most of 3. BittWare plans a future build option that provides a mixer for up and down conversion up to 35 GHz. To learn more, ask for our 35 GHz data sheet.

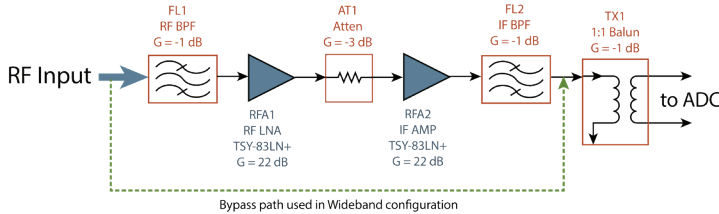

Transmit Side

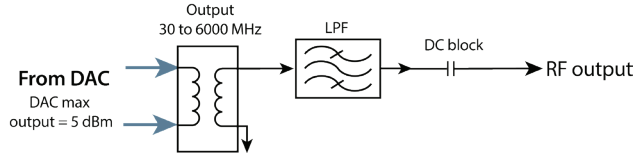

Included IP

BittWare RFX cards ship with an application that converts between analog data and timestamped, VITA-49.2 packets. It works in both ADC and DAC directions. The application also transfers raw data between the RFSoc and the ARM memory or eMMC. The RFSoc's ARM Processing System runs Linux and acts as a control plane. More specifically, BittWare has integrated card management functions through customized Linux drivers. BittWare has also ported AMD's RF Tool application, a socket library that configures an RFSoc chip. Above both Linux and the RF Tool, BittWare provides its own RFUtils commands and examples. RFUtils can generate synthetic waveforms as well as load and stream waveforms from files. All of this is fully supported by BittWare and we provide source code.

BittWare also supplies an unsupported port of AMD's RF Analyzer which we use to help characterize our cards.

Analog Characterization Data

BittWare fully tests and documents the analog characteristics of each RFX 880 configuration, whether wideband or amplified. That data is available for each significant printed circuit board (PCB) revision, roughly one month after a new PCB passes through manufacturing. The reports are available to customers through developer.bittware.com.

Clock Tree

The RFX 880 card offers a very flexible clock tree. It can accommodate reference clock inputs from Synchronous Ethernet, eCPRI, CPRI, as well as reference clocks fed in directly over coax cables. The default card configuration also has a 10 MHz OCXO and a 125 MHz fixed VCXO. Some of the RFX 880 clock tree flexibility is established through build options when the card is manufactured. BittWare will configure optimized cards for each customer, with a minimum quantity requirement in each order.

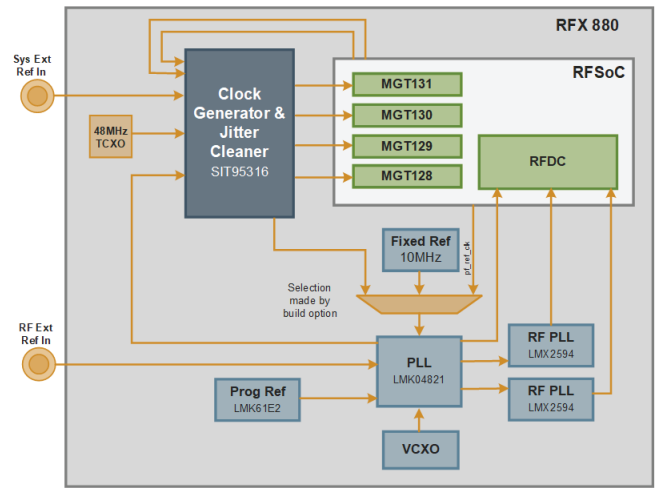

Chassis Options

BittWare offers a WaveBox Pi chassis that holds up to three RFX 880 cards in 1U. There is no motherboard inside. Alternatively, if you want to control the RFX 880 over PCIe, BittWare offers its WaveBox Sigma chassis. Both versions of WaveBox require an RFX 880 that isn't as wide as a standard, dual-slot PCIe card. If you wish to provide your own chassis, you can order the RFX 880 built a little wider to fit into a generic server's PCIe backplane.



WaveBox

RFX 880

Ethernet RFSoc Card

Board Specifications

RFSoc	<ul style="list-style-type: none">• AMD Zynq UltraScale+ RFSoc<ul style="list-style-type: none">• XCZU43 in a G1517 package• Core speed grade -2
Analog	<ul style="list-style-type: none">• 4x 5 GSPS 14-bit ADCs<ul style="list-style-type: none">• Wideband build option provides +0 to -27 dB gain from 50 MHz to 6 GHz with no filtration• 1st Nyquist (L-Band) build option provides +44 to -29 dB on all 4 channels, constrained between 400 MHz and 2.5 GHz by filters FL1 and FL2• 2nd and 3rd Nyquist filters are also available on amplified channels as a special order• 4x 9.7 GSPS 14-bit DACs<ul style="list-style-type: none">• Range of about +3 to -24 dBm• High power end of this range is a function of frequency• Constrained by a 4.8 GHz LPF• Programmable clocks• External reference and triggers• Push-on SMPM connectors with optional SMA pigtails
On-board flash	<ul style="list-style-type: none">• PS connects to a pair of 2Gb QSPI parts configured in "Dual Parallel" mode. The PS boots from the QSPI to configure itself, then pulls the logic bitstream from the QSPI and configures the PL• 32GB eMMC for ARM disk
External memory	<ul style="list-style-type: none">• Processing system: 16GB, 64-bit DDR4-2400 with ECC• Programmable logic: 32GB, 2x banks 64-bit DDR4-2666 with ECC (our example uses it as 36GB no ECC, 72-bit)
External digital interfaces	<ul style="list-style-type: none">• Processing system<ul style="list-style-type: none">• PCIe Gen2 x4• Dual RJ45 Ethernet, one on the front panel, second inside the chassis• Single USB for UART and JTAG, dual connectors. One on the front panel, second inside the chassis.• Programmable logic:<ul style="list-style-type: none">• Up to 400 Gb/s available via front panel 2x QSFP-DD• AMD Hard IP support for dual 100GbE

Cooling	<ul style="list-style-type: none">• Standard: double-width passive heatsink• Contact BittWare for other cooling options
Electrical	<ul style="list-style-type: none">• On-board power derived from 6-pin AUX connector• Power dissipation is application dependent• Typical max power consumption 50W
Environmental	<ul style="list-style-type: none">• Designed to operate between +5C and +40C chassis air inlet temperature, noncondensing (air temperature inside the chassis between +5C and +60C)
Quality	<ul style="list-style-type: none">• Manufactured to IPC-A-610 Class 2• RoHS compliant• CE, FCC, UKCA & ICES approvals
Form factor	<ul style="list-style-type: none">• ¾-length, standard-height PCIe dual-slot card (x16 mechanical)• Supports standalone operation• BittWare's WaveBox Pi chassis was specifically designed to house RFX 880 cards

Development Tools

Firmware development	BittWare provides interface software support for an example bitstream that fully configures the RFSoc chip using a scripting language running on the RFSoc's ARM. AMD Vivado development tools are fully supported for development of custom designs.
----------------------	---

Deliverables

- RFX 880 RFSoc Transceiver
- Data capture and relay example - Full source code
- 1-year hardware warranty

Sales Order Numbers

Contact BittWare for sales order numbers. For **initial evaluation**, we urge customers to buy an RFX 880 integrated into a WaveBox Pi chassis:

- **Wideband:** order WaveBox-Pi-Eval-1
- **Nyquist 1:** order WaveBox-Pi-Eval-2

Interested in purchasing? We offer direct sales at BittWare.com, or you can check stock with our distributors at BittWare.com/rfx880.

To learn more, visit www.BittWare.com

r0 v1 | last revised 2025.03.10

© BittWare 2025

UltraScale+, Zynq, and RFSoc are registered trademarks of AMD Corp. All other products are the trademarks or registered trademarks of their respective holders.

BittWare
a **molex** company